

distinte di taglio cutting sezes

atlantis

serie wood slide
serie wood slide TT

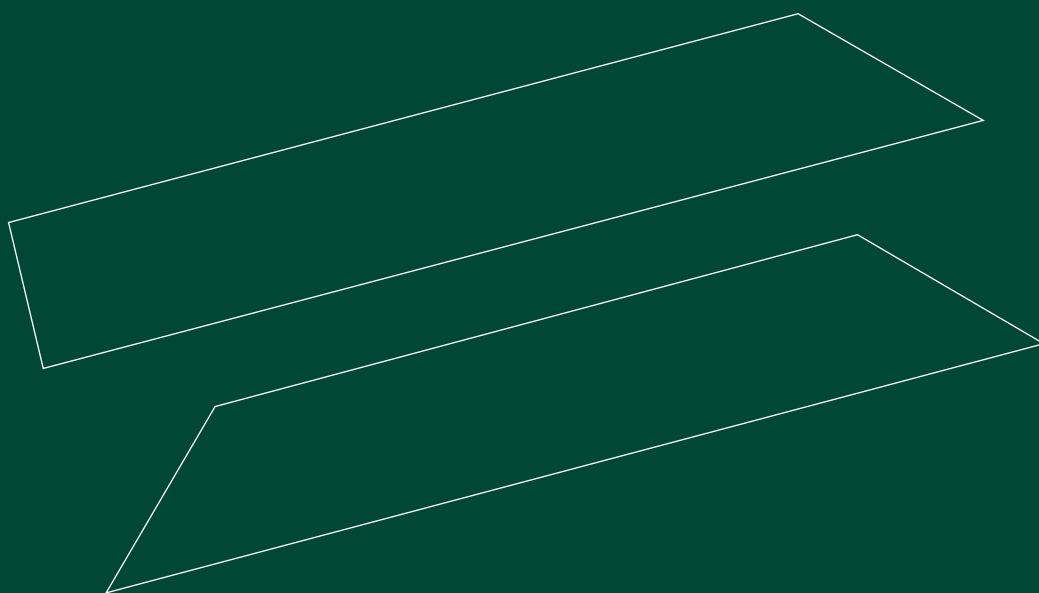

TO.MA. S.p.a.

ESTRUSIONE ALLUMINIO

WOOD SLIDE TT - scorrevole a due ante -

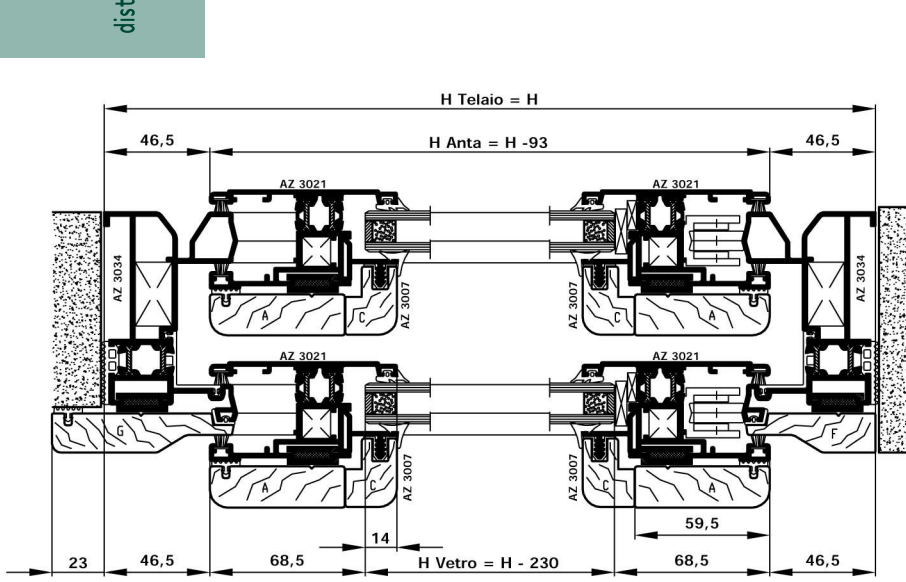

CALCOLO PESO PROFILI		TOTALE
	KG	
Profili Orizz.	$10,5 \times L$	
Profili Vert.	$11,7 \times H$	
TOTALE		

CALCOLO LUNGHEZZE TEORICHE LEGNI		TOTALE
	mm	ml
A	$4H + 2L - 416$	
B	$H - 93$	
C	$4H + 2L - 1368$	
G	$2H + L + 138$	
F	L	

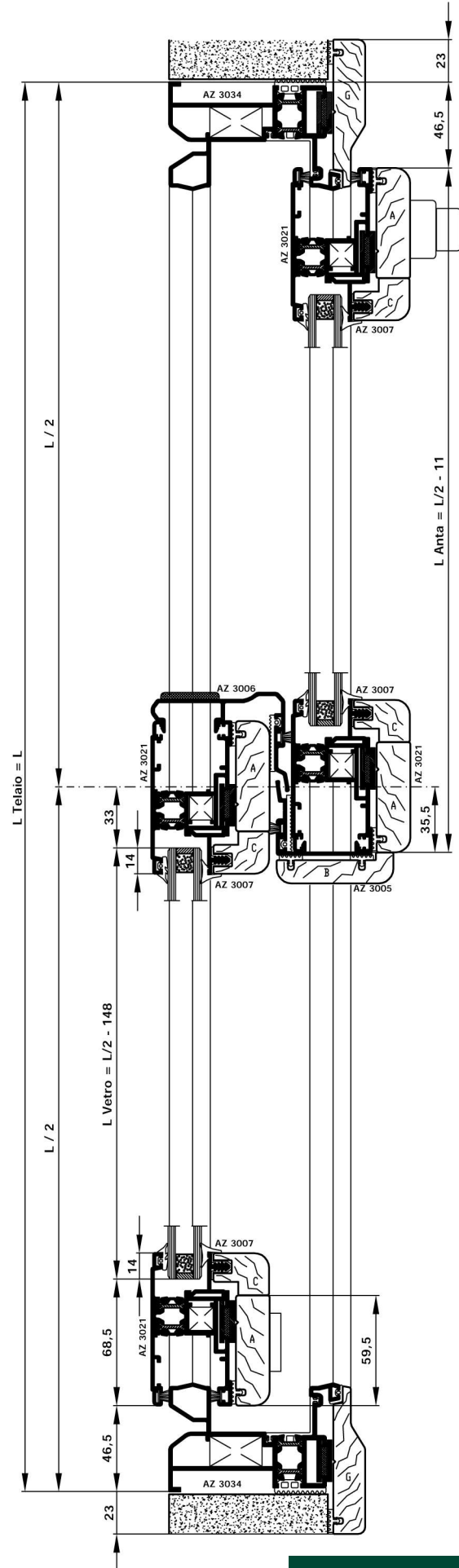
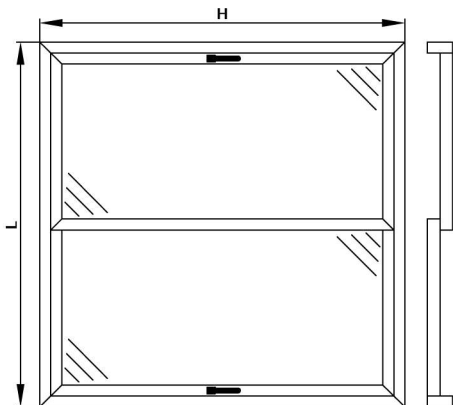

DISTINTA TAGLIO PROFILI

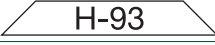
Nr. Pezzi	CODICI	DESCRIZIONE	TAGLIO
2	AZ 3034	MONTANTE TELAIO	 H
2	AZ 3034	TRAVERSO TELAIO	 L
4	AZ 3021	MONTANTE ANTA	 H-93
4	AZ 3021	TRAVERSA ANTA	 L/2-11
4	AZ 3007	FERMAVETRO TRAV.	 L/2-176
4	AZ 3007	FERMAVETRO MONT.	 H-258
1	AZ 3005	RISCONTRO CENT. INT.	 H-93
1	AZ 3006	RISCONTRO CENT. EST.	 H-93

DISTINTA TAGLIO LEGNI

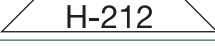
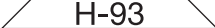
Nr. Pezzi	CODICI	DESCRIZIONE	TAGLIO
2	G	LEGNO TELAIO MONT.	 H+46
1	G	LEGNO TELAIO TRAV. SUP.	 L+46
1	F	LEGNO TELAIO TRAV. INF.	 L
4	A	LEGNO ANTA MONT.	 H-93
4	A	LEGNO ANTA TRAV.	 L/2-11
4	C	LEGNO FERMAVETRO MONT.	 H-212
4	C	LEGNO FERMAVETRO TRAV.	 L/2-130
1	B	LEGNO RISCONTRO CENT.	 H-93

GUARNIZIONI

ART.	DESCRIZIONE	N° P.zzi
Rg 355	G. DI FINITURA	2L + 2H
Rg 339	G. ISOL. LEGNO-ALL TELAIO	2L + 2H
Rg 341	G. ISOLAMENTO SOGLIA	2L + 2H
Rg 301	SPAZZOLINO	6L + 8H
Rg 342	G. ISOL. LEGNO-ALL	8L + 5H
Rg 334	G. FISSAGGIO FERMAVETRO	4L + 4H
Rg 345	G. VETRO INTERNA	4L + 4H
Rg 351	G. VETRO ESTERNA	4L + 4H
Rg 340	G. NODO CENTRALE	2L

ACCESSORI

ART.	DESCRIZIONE	N° P.zzi
Ra 1033	CAPPETTA DI SCARICO ACQUA	2
Ra 2302	BLOCCETTO UNIONE LEGNO ALLUMINIO	1 ogni 200 mm
Ra 2600	REGOLATORE A MURO	10
Ra 2601	BOCCOLA SCARICO ACQUA	3
Ra 2602	SQUADRETTA ANTA AZ 3021	8
Ra 2608	SQUADRETTA PER TELAIO	4
Ra 2618	SQUADRETTA DI ALLINEAMENTO ANTE	8
Ra 2603	TASSELLO AMMORTIZZATORE E ANTIFILAMENTO ANTA	4
Ra 2609	TAPPO COPRILAVORAZIONE	4
Ra 2606	TASSELLO DI TENUTA CENTRALE	2
Ra 2607	CARRELLO SCORREVOLE REGISTRABILE PORTATA MASSIMA PER ANTA 150 Kg	4

È ESCLUSA LA FERRAMENTA DI MOVIMENTAZIONE

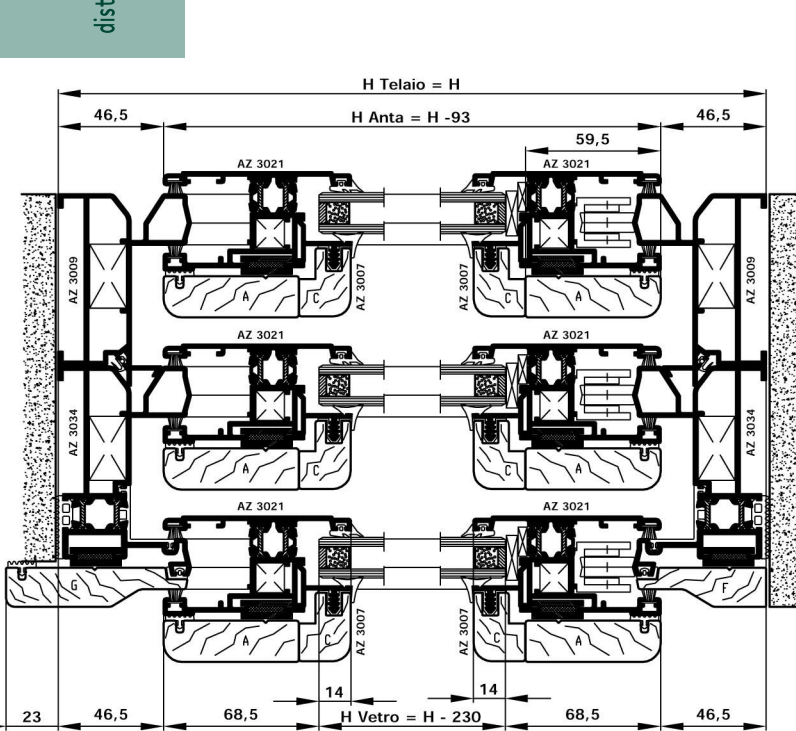



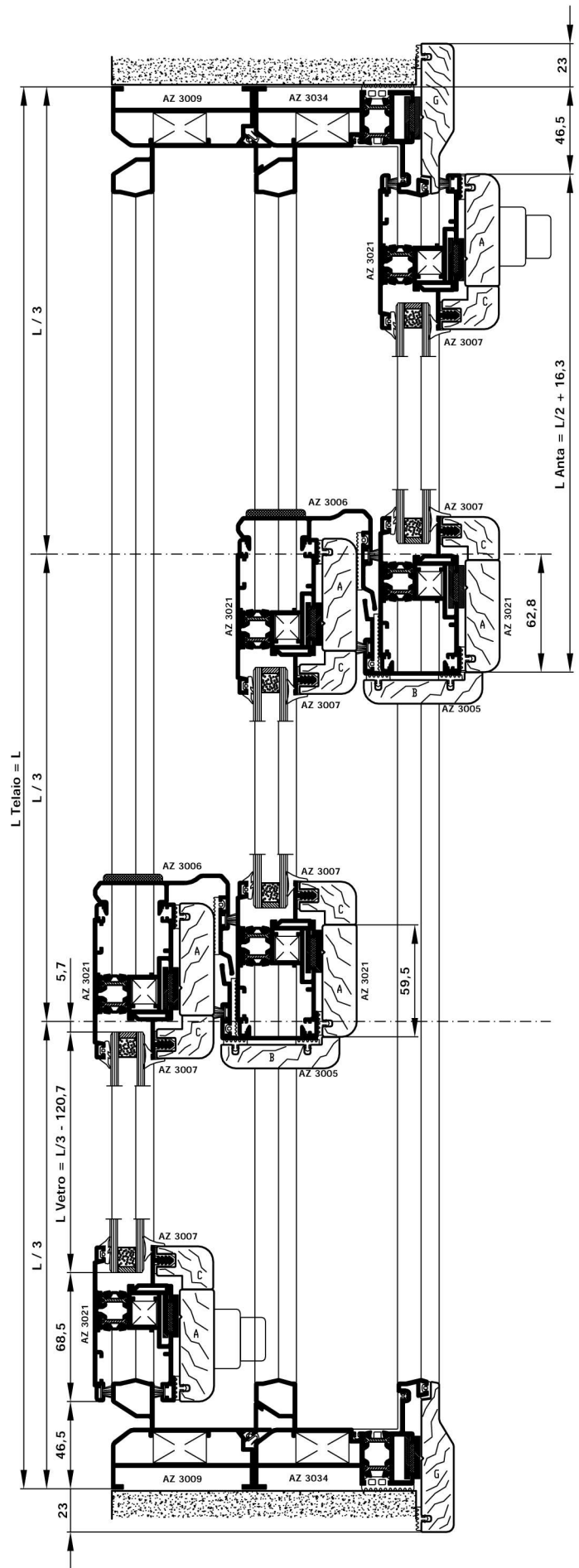
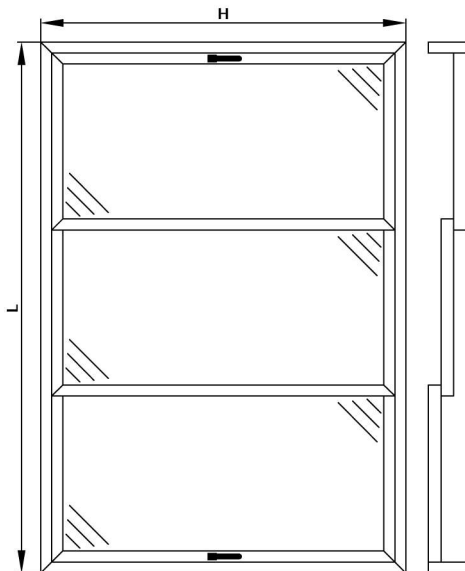

CALCOLO PESO PROFILI		TOTALE
		KG
Profili Orizz.	$\frac{\text{Kg/ml}}{16,7} \times L$	
Profili Vert.	$\frac{\text{Kg/ml}}{19} \times H$	
TOTALE		



CALCOLO LUNGHEZZE TEORICHE LEGNI		TOTALE
		ml
A	$6H + 3L - 460 \text{ mm}$	
B	$2H - 186 \text{ mm}$	
C	$6H + 3L - 660 \text{ mm}$	
G	$2H + L + 138 \text{ mm}$	
F	L	

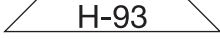
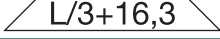
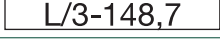
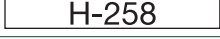
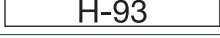
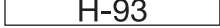

DISTINTA TAGLIO PROFILI

Nr. Pezzi	CODICI	DESCRIZIONE	TAGLIO
2	AZ 3034	MONTANTE TELAIO	 H
2	AZ 3009	MONTANTE TELAIO	 H
2	AZ 3034	TRAVERSO TELAIO	 L
2	AZ 3009	TRAVERSO TELAIO	 L
6	AZ 3021	MONTANTE ANTA	 H-93
6	AZ 3021	TRAVERSA ANTA	 L/3+16,3
6	AZ 3007	FERMAVETRO TRAV.	 L/3-148,7
6	AZ 3007	FERMAVETRO MONT.	 H-258
2	AZ 3005	RISCONTRO CENT. INT.	 H-93
2	AZ 3006	RISCONTRO CENT. EST.	 H-93

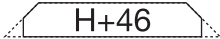
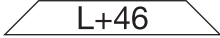
DISTINTA TAGLIO LEGNI

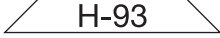
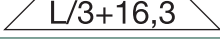
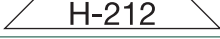
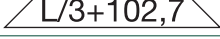
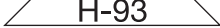
Nr. Pezzi	CODICI	DESCRIZIONE	TAGLIO
2	G	LEGNO TELAIO MONT.	 H+46
1	G	LEGNO TELAIO TRAV. SUP.	 L+46
1	F	LEGNO TELAIO TRAV. INF.	 L
6	A	LEGNO ANTA MONT.	 H-93
6	A	LEGNO ANTA TRAV.	 L/3+16,3
6	C	LEGNO ANTA MONT.	 H-212
6	C	LEGNO ANTA TRAV.	 L/3+102,7
2	B	LEGNO RISCONTRO CENT.	 H-93

GUARNIZIONI

ART.	DESCRIZIONE	N° P.zzi
Rg 355	G. ANTI POLVERE PER TELAIO	2L + 2H
Rg 339	G. ISOL. LEGNO-ALL TELAIO	2L + 2H
Rg 341	G. ISOLAMENTO SOGLIA	2L + 2H
Rg 301	G. A SPAZZOLA	8L + 12H
Rg 342	G. ISOL. LEGNO-ALL LEGNO	12L + 7H
Rg 334	G. FISSAGGIO FERMAVETRO	6L + 6H
Rg 345	G. VETRO INTERNA	6L + 6H
Rg 351	G. VETRO ESTERNA	6L + 6H
Rg 340	G. NODO CENTRALE ANTA	4L
Rg 402	G. NODO CENTRALE TELAIO	2L + 2H

ACCESSORI

ART.	DESCRIZIONE	N° P.zzi
Ra 1033	CAPPETTA DI SCARICO ACQUA	3
Ra 2302	BLOCCHETTO UNIONE LEGNO ALLUMINIO	1 ogni 200 mm
Ra 2600	REGOLATORE A MURO	12
Ra 2601	BOCCOLA SCARICO ACQUA	6
Ra 2602	SQUADRETTA ANTA AZ 3021	12
Ra 2608	SQUADRETTA PER TELAIO	8
Ra 2618	SQUADRETTA DI ALLINEAMENTO ANTE	12
Ra 2603	TASSELLO AMMORTIZZATORE E ANTIFILAMENTO ANTA	6
Ra 2609	TAPPO COPRILAVORAZIONE	8
Ra 2606	TASSELLO DI TENUTA CENTRALE	4
Ra 2607	CARRELLO SCORREVOLE REGISTRABILE PORTATA MASSIMA PER ANTA 150 Kg	6

È ESCLUSA LA FERRAMENTA DI MOVIMENTAZIONE

WOOD SLIDE TT - scorrevole a quattro ante -

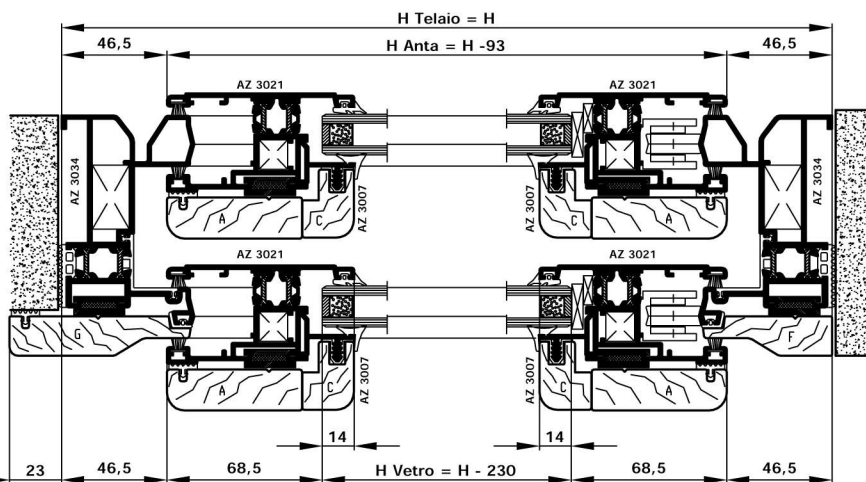

CALCOLO PESO PROFILI		TOTALE
		KG
Profili Orizz.	Kg/ml $17,3 \times L$	
Profili Vert.	Kg/ml $20,1 \times H$	
TOTALE		

CALCOLO LUNGHEZZE TEORICHE LEGNI		TOTALE
		ml
A	$8H + 4L - 658 \text{ mm}$	
B	$2H - 186 \text{ mm}$	
C	$8H + 4L - 830 \text{ mm}$	
G	$2H + L + 138 \text{ mm}$	
F	L	

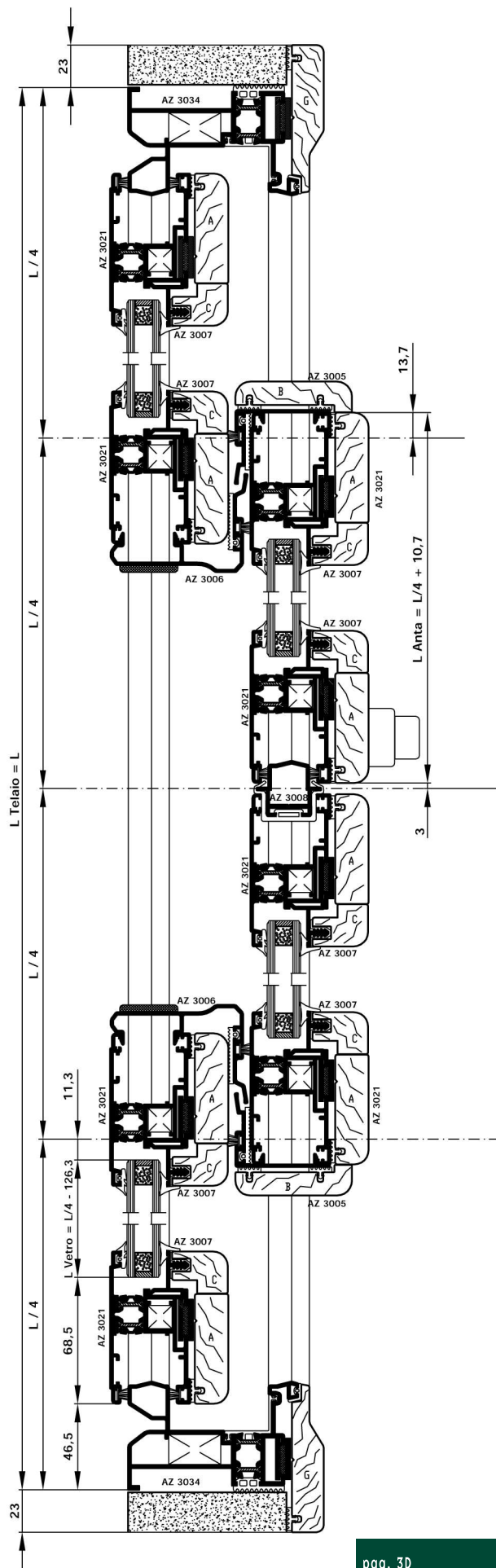
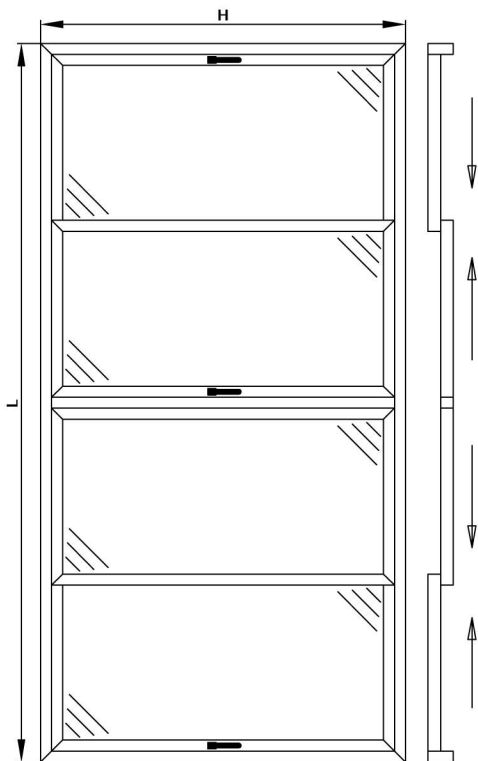

DISTINTA TAGLIO PROFILI

Nr. Pezzi	CODICI	DESCRIZIONE	TAGLIO
2	AZ 3034	MONTANTE TELAIO	 H
2	AZ 3034	TRAVERSO TELAIO	 L
8	AZ 3021	MONTANTE ANTA	 H-93
8	AZ 3021	TRAVERSA ANTA	 L/4+10,7
8	AZ 3007	FERMAVETRO TRAV.	 L/4-154,3
8	AZ 3007	FERMAVETRO MONT.	 H-258
2	AZ 3005	RISCONTRO CENT. INT.	 H-93
2	AZ 3006	RISCONTRO CENT. EST.	 H-93

DISTINTA TAGLIO LEGNI

Nr. Pezzi	CODICI	DESCRIZIONE	TAGLIO
2	G	LEGNO TELAIO MONT.	 H+46
1	G	LEGNO TELAIO TRAV. SUP.	 L+46
1	F	LEGNO TELAIO TRAV. INF.	 L
8	A	LEGNO ANTA MONT.	 H-93
8	A	LEGNO ANTA TRAV.	 L/4+10,7
8	C	LEGNO FERMAVETRO MONT.	 H-212
8	C	LEGNO FERMAVETRO TRAV.	 L/4+108,3
2	B	LEGNO RISCONTRO CENT.	 H-93

GUARNIZIONI

ART.	DESCRIZIONE	N° P.zzi
Rg 355	G. ANTI POLVERE PER TELAIO	2L + 2H
Rg 339	G. ISOL. LEGNO-ALL TELAIO	2L + 2H
Rg 341	G. ISOLAMENTO SOGLIA	2L + 2H
Rg 301	G. A SPAZZOLA	10L + 16H
Rg 342	G. ISOL. LEGNO-ALL LEGNO	14L + 9H
Rg 334	G. FISSAGGIO FERMAVETRO	8L + 8H
Rg 345	G. VETRO INTERNA	8L + 8H
Rg 351	G. VETRO ESTERNA	8L + 8H
Rg 340	G. NODO CENTRALE ANTA	4L
Rg 343	G. NODO CENTRALE 4 ANTE	1L

ACCESSORI

ART.	DESCRIZIONE	N° P.zzi
Ra 1033	CAPPETTA DI SCARICO ACQUA	4
Ra 2302	BLOCCHETTO UNIONE LEGNO ALLUMINIO	1 ogni 200 mm
Ra 2600	REGOLATORE A MURO	14
Ra 2601	BOCCOLA SCARICO ACQUA	6
Ra 2602	SQUADRETTA ANTA AZ 3021	16
Ra 2608	SQUADRETTA PER TELAIO	8
Ra 2618	SQUADRETTA DI ALLINEAMENTO ANTE	16
Ra 2603	TASSELLO AMMORTIZZATORE E ANTIFILAMENTO ANTA	8
Ra 2609	TAPPO COPRILAVORAZIONE	8
Ra 2606	TASSELLO DI TENUTA CENTRALE	6
Ra 2607	CARRELLO SCORREVOLE REGISTRABILE PORTATA MASSIMA PER ANTA 150 Kg	8



È ESCLUSA LA FERRAMENTA DI MOVIMENTAZIONE

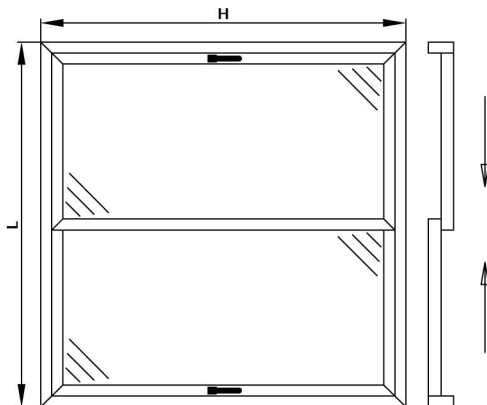
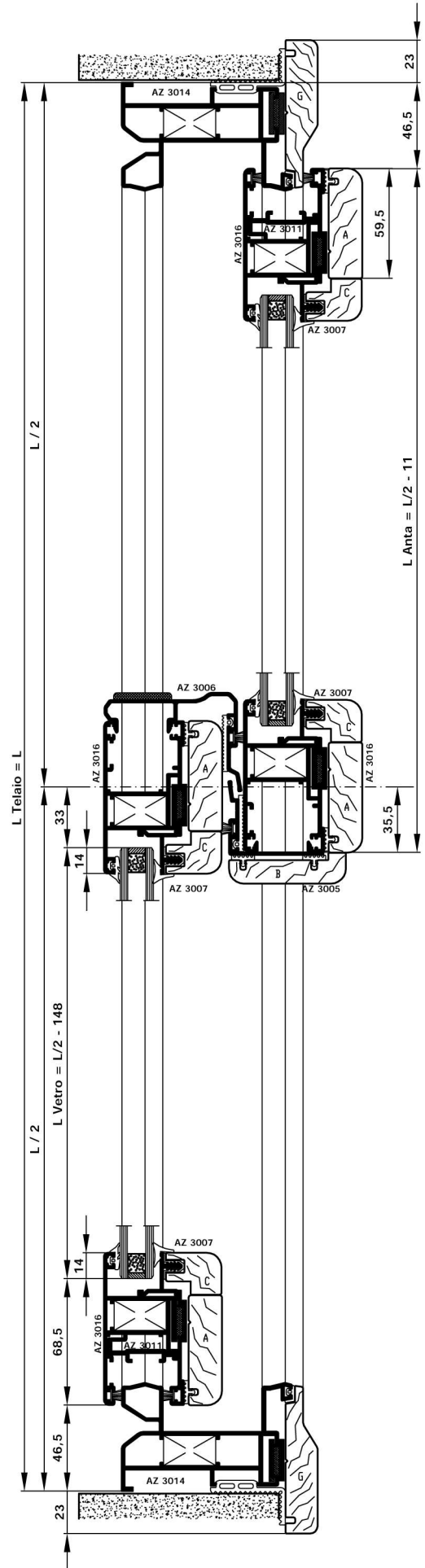
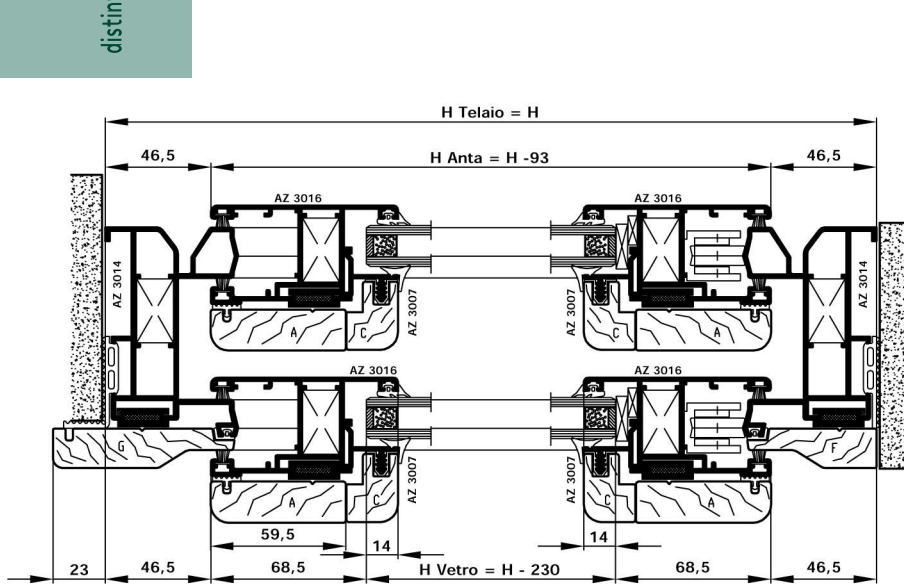

WOOD SLIDE - scorrevole a due ante -
- ante con fermavetro -

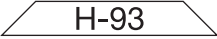
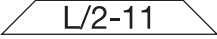
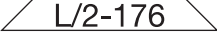
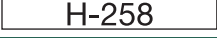
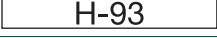
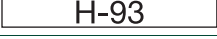
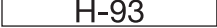

CALCOLO PESO PROFILI		TOTALE
Profili Orizz.	Kg/ml 8,9 x L	KG
Profili Vert.	Kg/ml 10 x H	
TOTALE		

CALCOLO LUNGHEZZE TEORICHE LEGNI		TOTALE
A	4H + 2L - 416 mm	ml
B	H - 93 mm	
C	4H + 2L - 1368 mm	
G	2H + L + 138 mm	
F	L	

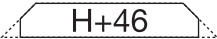
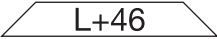
DISTINTA TAGLIO PROFILI			
Nr. Pezzi	CODICI	DESCRIZIONE	TAGLIO
2	AZ 3014	MONTANTE TELAIO	 H
2	AZ 3014	TRAVERSO TELAIO	 L
4	AZ 3016	MONTANTE ANTA	 H-93
4	AZ 3016	TRAVERSA ANTA	 L/2-11
4	AZ 3007	FERMAVETRO TRAV.	 L/2-176
4	AZ 3007	FERMAVETRO MONT.	 H-258
1	AZ 3005	RISCONTRO CENT. INT.	 H-93
1	AZ 3006	RISCONTRO CENT. EST.	 H-93
2	AZ 3011	ASTA DI CHIUSURA	 H-93

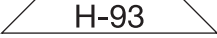
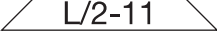
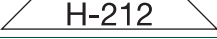
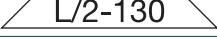
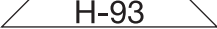
DISTINTA TAGLIO LEGNI			
Nr. Pezzi	CODICI	DESCRIZIONE	TAGLIO
2	G	LEGNO TELAIO MONT.	 H+46
1	G	LEGNO TELAIO TRAV. SUP.	 L+46
1	F	LEGNO TELAIO TRAV. INF.	 L
4	A	LEGNO ANTA MONT.	 H-93
4	A	LEGNO ANTA TRAV.	 L/2-11
4	C	LEGNO ANTA MONT.	 H-212
4	C	LEGNO ANTA TRAV.	 L/2-130
1	B	LEGNO RISCONTRO CENT.	 H-93

GUARNIZIONI		
ART.	DESCRIZIONE	N° P.zzi
Rg 339	G. ISOL. LEGNO-ALL TELAIO	2L + 2H
Rg 354	G. ISOLAMENTO SOGLIA	2L + 2H
Rg 301	G. A SPAZZOLA	6L + 8H
Rg 342	G. ISOL. LEGNO-ALL LEGNO	8L + 5H
Rg 334	G. FISSAGGIO FERMAVETRO	4L + 4H
Rg 345	G. VETRO INTERNA	4L + 4H
Rg 351	G. VETRO ESTERNA	4L + 4H
Rg 340	G. NODO CENTRALE	2L

ACCESSORI		
ART.	DESCRIZIONE	N° P.zzi
Ra 1033	CAPPETTA DI SCARICO ACQUA	2
Ra 2302	BLOCCHETTO UNIONE LEGNO ALLUMINIO	1 ogni 200 mm
Ra 2600	REGOLATORE A MURO	10
Ra 2601	BOCCOLA SCARICO ACQUA	2
Ra 2608	SQUADRETTA PER TELAIO E ANTA	12
Ra 2618	SQUADRETTA DI ALLINEAMENTO ANTE	8
Ra 2603	TASSELLO AMMORTIZZATORE E ANTIFILAMENTO ANTA	8
Ra 2609	TAPPO COPRILAVORAZIONE	2
Ra 2606	TASSELLO DI TENUTA CENTRALE	2
Ra 2607	CARRELLO SCORREVOLE REGISTRABILE PORTATA MASSIMA PER ANTA 150 Kg	4

È ESCLUSA LA FERRAMENTA DI MOVIMENTAZIONE

WOOD SLIDE - scorrevole a tre ante -
- ante con fermavetro -

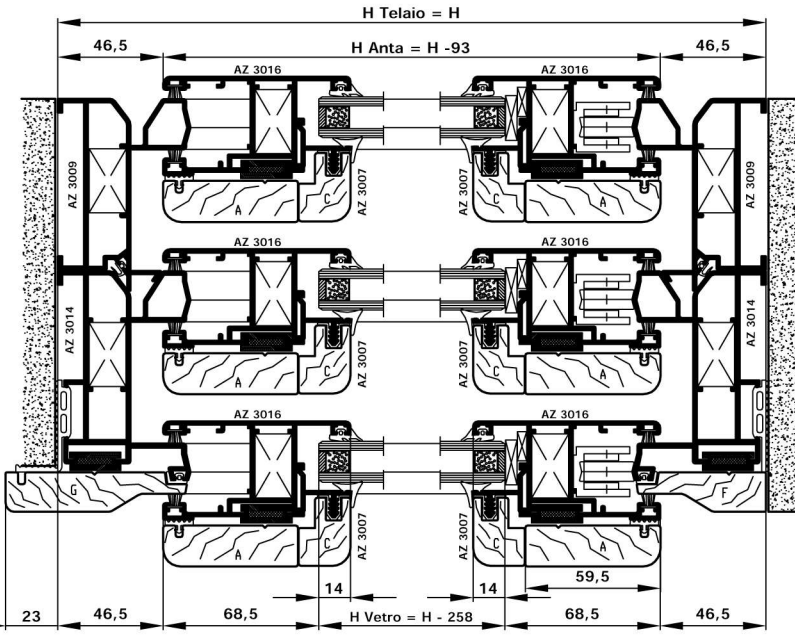



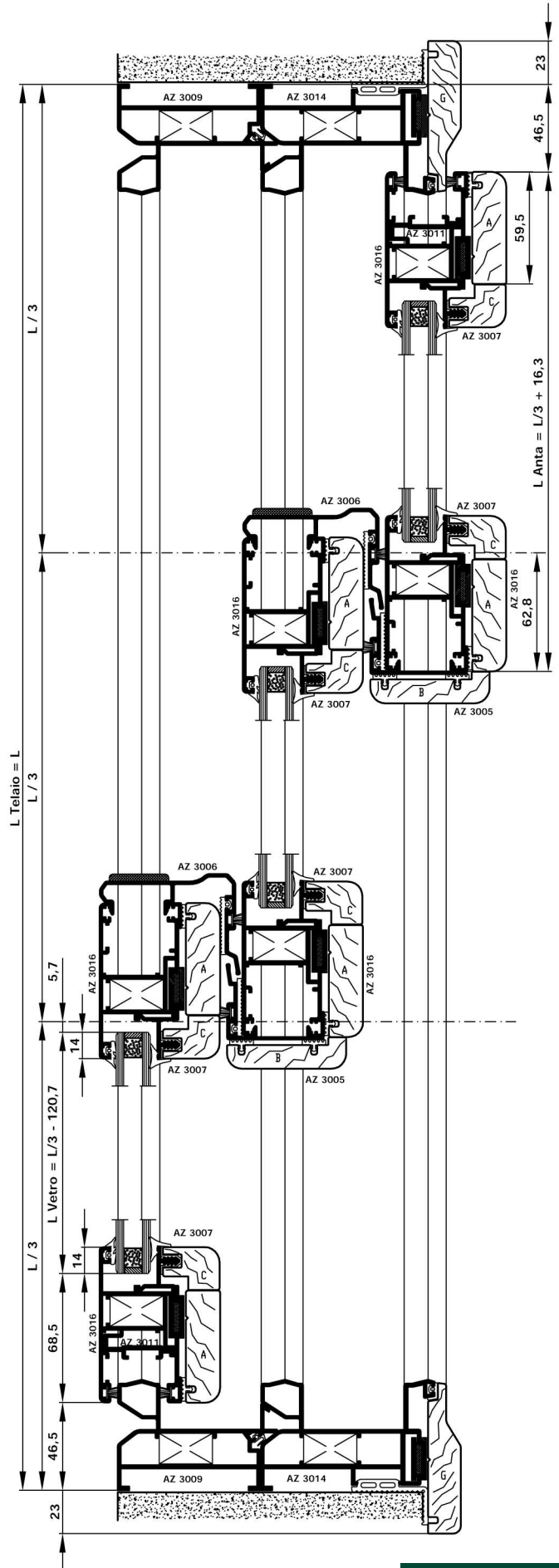
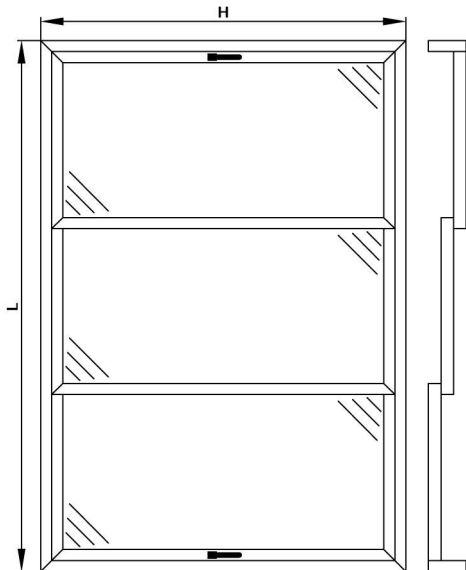

CALCOLO PESO PROFILI		TOTALE
Profili Orizz.	Kg/ml 14,5 x L	KG
Profili Vert.	Kg/ml 16,7 x H	
TOTALE		



CALCOLO LUNGHEZZE TEORICHE LEGNI		TOTALE
A	6H + 3L - 460 mm	ml
B	2H - 186 mm	
C	6H + 3L - 657 mm	
G	2H + L + 138 mm	
F	L	

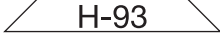
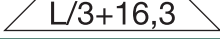
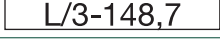
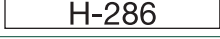
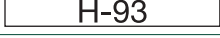
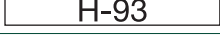
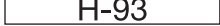

DISTINTA TAGLIO PROFILI

Nr. Pezzi	CODICI	DESCRIZIONE	TAGLIO
2	AZ 3009	MONTANTE TELAIO	 H
2	AZ 3014	MONTANTE TELAIO	 H
2	AZ 3009	TRAVERSO TELAIO	 L
2	AZ 3014	TRAVERSO TELAIO	 L
6	AZ 3016	MONTANTE ANTA	 H-93
6	AZ 3016	TRAVERSA ANTA	 L/3+16,3
6	AZ 3007	FERMAVETRO TRAV.	 L/3-148,7
6	AZ 3007	FERMAVETRO MONT.	 H-286
2	AZ 3005	RISCONTRO CENT. INT.	 H-93
2	AZ 3006	RISCONTRO CENT. EST.	 H-93
2	AZ 3011	ASTA DI CHIUSURA	 H-93

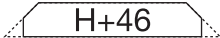
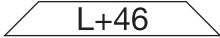
DISTINTA TAGLIO LEGNI

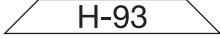
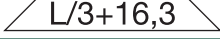
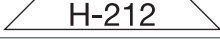
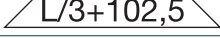
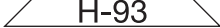
Nr. Pezzi	CODICI	DESCRIZIONE	TAGLIO
2	G	LEGNO TELAIO MONT.	 H+46
1	G	LEGNO TELAIO TRAV. SUP.	 L+46
1	F	LEGNO TELAIO TRAV. INF.	 L
6	A	LEGNO ANTA MONT.	 H-93
6	A	LEGNO ANTA TRAV.	 L/3+16,3
6	C	LEGNO ANTA MONT.	 H-212
6	C	LEGNO ANTA TRAV.	 L/3+102,5
2	B	LEGNO RISCONTRO CENT.	 H-93

GUARNIZIONI

ART.	DESCRIZIONE	N° P.zzi
Rg 339	G. ISOL. LEGNO-ALL TELAIO	2L + 2H
Rg 354	G. ISOLAMENTO SOGLIA	2L + 2H
Rg 301	G. A SPAZZOLA	8L + 12H
Rg 342	G. ISOL. LEGNO-ALL LEGNO	12L + 7H
Rg 334	G. FISSAGGIO FERMAVETRO	6L + 6H
Rg 345	G. VETRO INTERNA	6L + 6H
Rg 351	G. VETRO ESTERNA	6L + 6H
Rg 340	G. NODO CENTRALE ANTA	4L
Rg 402	G. NODO CENTRALE TELAIO	2L + 2H

ACCESSORI

ART.	DESCRIZIONE	N° P.zzi
Ra 1033	CAPPETTA DI SCARICO ACQUA	3
Ra 2302	BLOCCHETTO UNIONE LEGNO ALLUMINIO	1 ogni 200 mm
Ra 2600	REGOLATORE A MURO	12
Ra 2601	BOCCOLA SCARICO ACQUA	6
Ra 2608	SQUADRETTA PER TELAIO E ANTA	20
Ra 2618	SQUADRETTA DI ALLINEAMENTO ANTE	12
Ra 2603	TASSELLO AMMORTIZZATORE E ANTIFILAMENTO ANTA	6
Ra 2609	TAPPO COPRILAVORAZIONE	8
Ra 2606	TASSELLO DI TENUTA CENTRALE	4
Ra 2607	CARRELLO SCORREVOLE REGISTRABILE PORTATA MASSIMA PER ANTA 150 Kg	6

È ESCLUSA LA FERRAMENTA DI MOVIMENTAZIONE

WOOD SLIDE - scorrevole a quattro ante -
- ante con fermavetro -

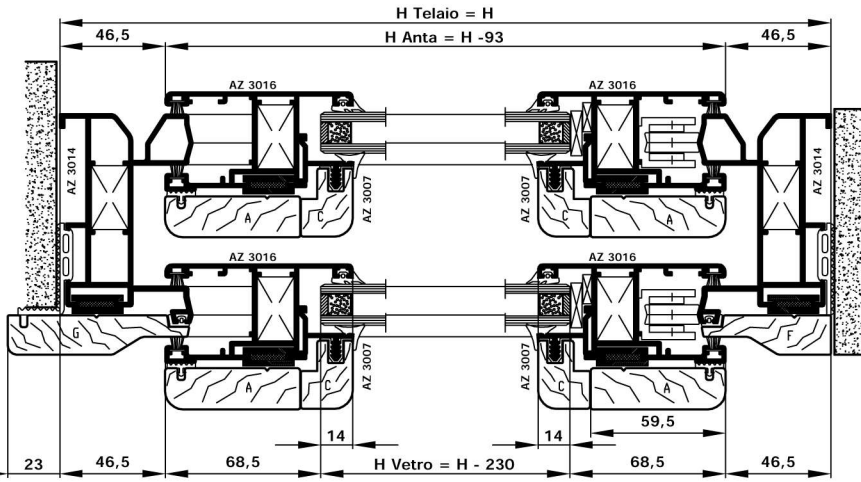
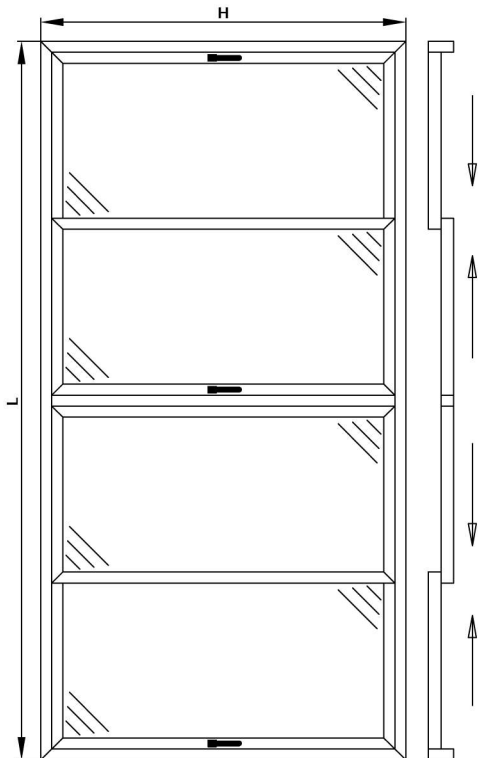

CALCOLO PESO PROFILI		TOTALE
Profili Orizz.	Kg/ml $14,5 \times L$	KG
Profili Vert.	Kg/ml $17,2 \times H$	
TOTALE		

CALCOLO LUNGHEZZE TEORICHE LEGNI		TOTALE
A	8H + 4L - 658 mm	ml
B	2H - 186 mm	
C	8H + 4L - 830 mm	
G	2H + L + 138 mm	
F	L	

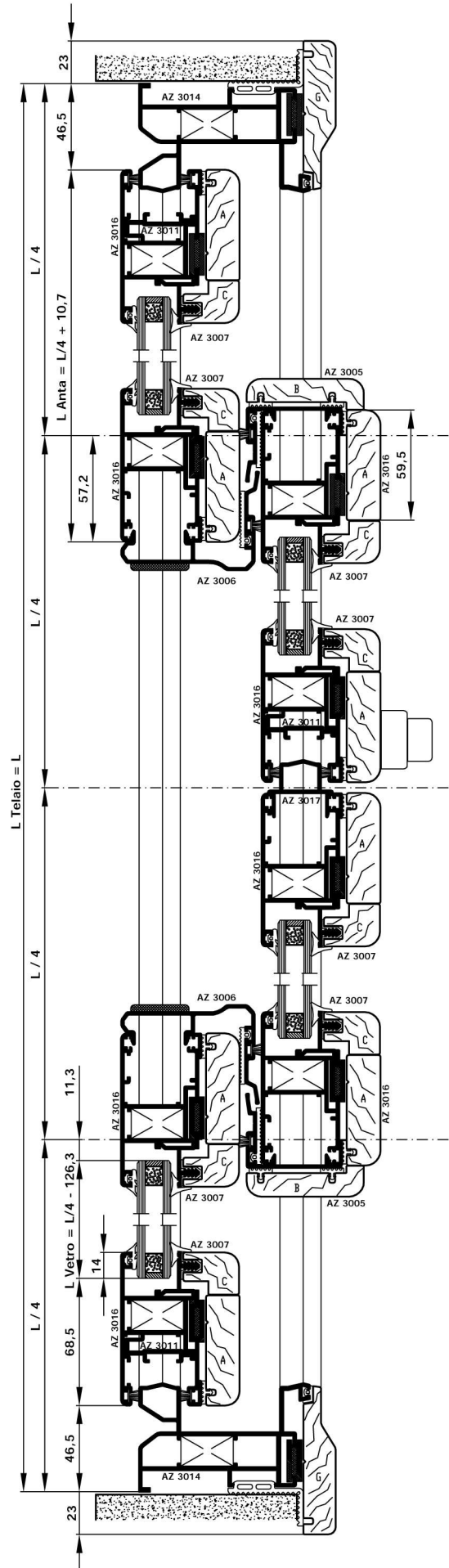

DISTINTA TAGLIO PROFILI

Nr. Pezzi	CODICI	DESCRIZIONE	TAGLIO
2	AZ 3014	MONTANTE TELAIO	 H
2	AZ 3014	TRAVERSO TELAIO	 L
8	AZ 3016	MONTANTE ANTA	 H-93
8	AZ 3016	TRAVERSA ANTA	 L/4+10,7
8	AZ 3007	FERMAVETRO TRAV.	 L/4-154,3
8	AZ 3007	FERMAVETRO MONT.	 H-258
2	AZ 3005	RISCONTRO CENT. INT.	 H-93
2	AZ 3006	RISCONTRO CENT. EST.	 H-93
3	AZ 3011	ASTA DI CHIUSURA	 H-93

DISTINTA TAGLIO LEGNI

Nr. Pezzi	CODICI	DESCRIZIONE	TAGLIO
2	G	LEGNO TELAIO MONT.	 H+46
1	G	LEGNO TELAIO TRAV. SUP.	 L+46
1	F	LEGNO TELAIO TRAV. INF.	 L
8	A	LEGNO ANTA MONT.	 H-93
8	A	LEGNO ANTA TRAV.	 L/4+10,7
8	C	LEGNO ANTA MONT.	 H-212
8	C	LEGNO ANTA TRAV.	 L/4+108,2
2	B	LEGNO RISCONTRO CENT.	 H-93

GUARNIZIONI

ART.	DESCRIZIONE	N° P.zzi
Rg 339	G. ISOL. LEGNO-ALL TELAIO	2L + 2H
Rg 354	G. ISOLAMENTO SOGLIA	2L + 2H
Rg 301	G. A SPAZZOLA	10L + 8H
Rg 342	G. ISOL. LEGNO-ALL LEGNO	14L + 5H
Rg 334	G. FISSAGGIO FERMAVETRO	8L + 8H
Rg 345	G. VETRO INTERNA	8L + 8H
Rg 351	G. VETRO ESTERNA	8L + 8H
Rg 340	G. NODO CENTRALE ANTA	4L

ACCESSORI

ART.	DESCRIZIONE	N° P.zzi
Ra 1033	CAPPETTA DI SCARICO ACQUA	4
Ra 2302	BLOCCHETTO UNIONE LEGNO ALLUMINIO	1 ogni 200 mm
Ra 2600	REGOLATORE A MURO	14
Ra 2601	BOCCOLA SCARICO ACQUA	6
Ra 2608	SQUADRETTA PER TELAIO E ANTA	24
Ra 2618	SQUADRETTA DI ALLINEAMENTO ANTE	16
Ra 2603	TASSELLO AMMORTIZZATORE E ANTIFILAMENTO ANTA	8
Ra 2609	TAPPO COPRILAVORAZIONE	8
Ra 2606	TASSELLO DI TENUTA CENTRALE	6
Ra 2607	CARRELLO SCORREVOLE REGISTRABILE PORTATA MASSIMA PER ANTA 150 Kg	8

È ESCLUSA LA FERRAMENTA DI MOVIMENTAZIONE

WOOD SLIDE - scorrevole a due ante -
- anta vetro ad infilare -

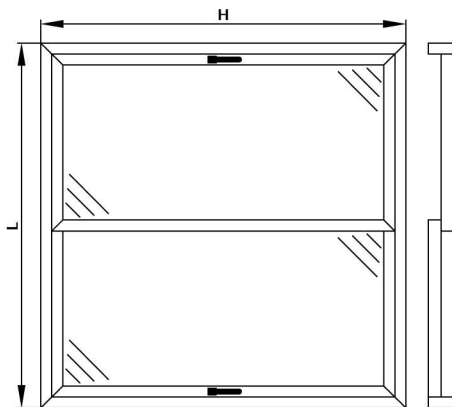

CALCOLO PESO PROFILI		TOTALE KG
Profili Orizz.	Kg/ml $8,1 \times L$	
Profili Vert.	Kg/ml $9,9 \times H$	
TOTALE		

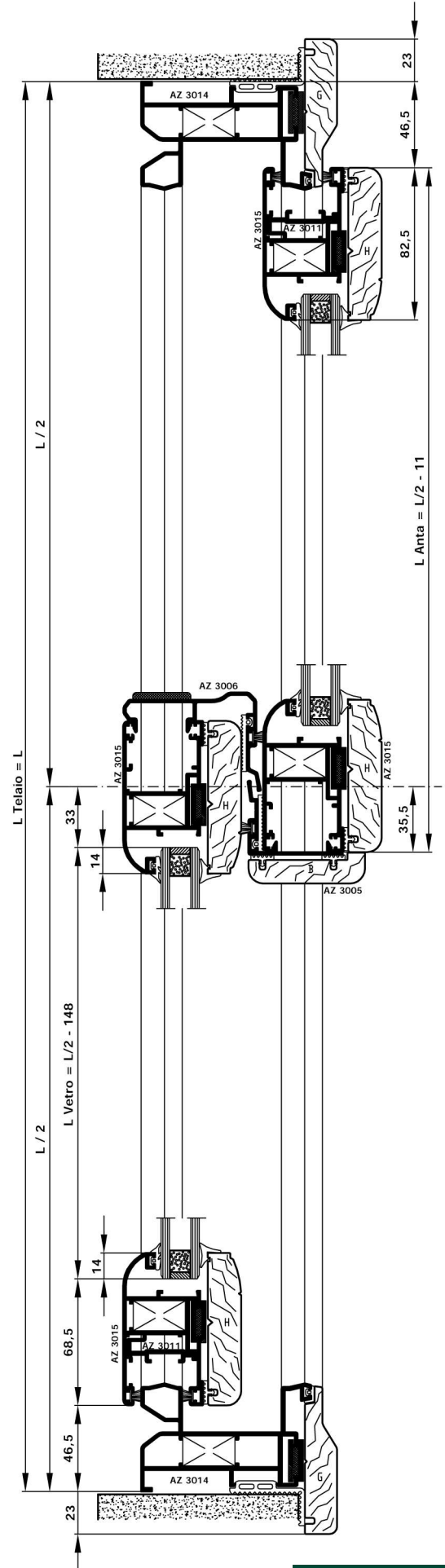
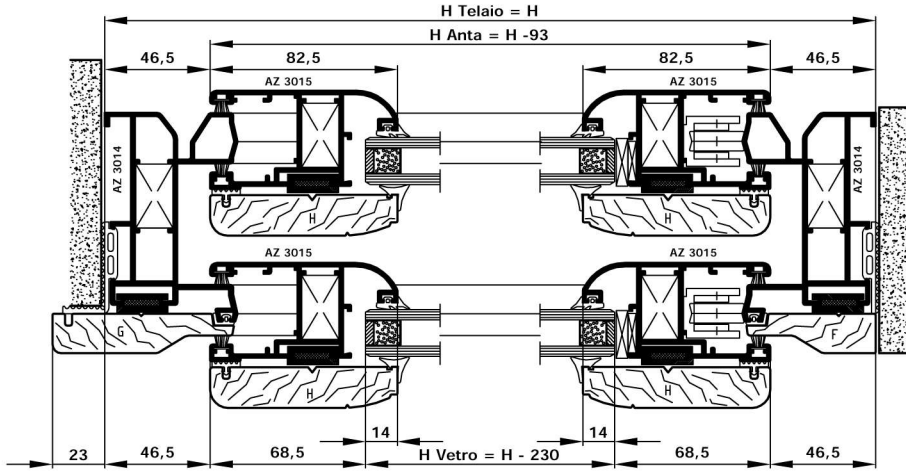

CALCOLO LUNGHEZZE TEORICHE LEGNI		TOTALE ml
B	H - 93 mm	
F	L	
G	2H + L + 138 mm	
H	4H + 2L - 964 mm	



DISTINTA TAGLIO PROFILI

Nr. Pezzi	CODICI	DESCRIZIONE	TAGLIO
2	AZ 3014	MONTANTE TELAIO	 H
2	AZ 3014	TRAVERSO TELAIO	 L
4	AZ 3015	MONTANTE ANTA	 H-93
4	AZ 3015	TRAVERSA ANTA	 L/2-11
1	AZ 3005	RISCONTRO CENT. INT.	 H-93
1	AZ 3006	RISCONTRO CENT. EST.	 H-93
2	AZ 3011	ASTA DI CHIUSURA	 H-93

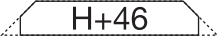
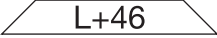
DISTINTA TAGLIO LEGNI

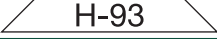
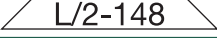
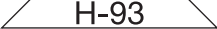
Nr. Pezzi	CODICI	DESCRIZIONE	TAGLIO
2	G	LEGNO TELAIO MONT.	 H+46
1	G	LEGNO TELAIO TRAV. SUP.	 L+46
1	F	LEGNO TELAIO TRAV. INF.	 L
4	H	LEGNO ANTA MONT.	 H-93
4	H	LEGNO ANTA TRAV.	 L/2-148
1	B	LEGNO RISCONTRO CENT.	 H-93

GUARNIZIONI

ART.	DESCRIZIONE	N° P.zzi
Rg 339	G. ISOL. LEGNO-ALL TELAIO	2L + 2H
Rg 354	G. ISOLAMENTO SOGLIA	2L + 2H
Rg 301	G. A SPAZZOLA	6L + 8H
Rg 342	G. ISOL. LEGNO-ALL LEGNO	8L + 5H
Rg 345	G. VETRO INTERNA	4L + 4H
Rg 351	G. VETRO ESTERNA	4L + 4H
Rg 340	G. NODO CENTRALE	2L

ACCESSORI

ART.	DESCRIZIONE	N° P.zzi
Ra 1033	CAPPETTA DI SCARICO ACQUA	2
Ra 2302	BLOCCHETTO UNIONE LEGNO ALLUMINIO	1 ogni 200 mm
Ra 2600	REGOLATORE A MURO	10
Ra 2601	BOCCOLA SCARICO ACQUA	2
Ra 2608	SQUADRETTA PER TELAIO E ANTA	12
Ra 2618	SQUADRETTA DI ALLINEAMENTO ANTE	8
Ra 2603	TASSELLO AMMORTIZZATORE E ANTISFILAMENTO ANTA	8
Ra 2609	TAPPO COPRILAVORAZIONE	2
Ra 2606	TASSELLO DI TENUTA CENTRALE	2
Ra 2607	CARRELLO SCORREVOLE REGISTRABILE PORTATA MASSIMA PER ANTA 150 Kg	4

È ESCLUSA LA FERRAMENTA DI MOVIMENTAZIONE

WOOD SLIDE - scorrevole a tre ante -
- anta vetro ad infilare -

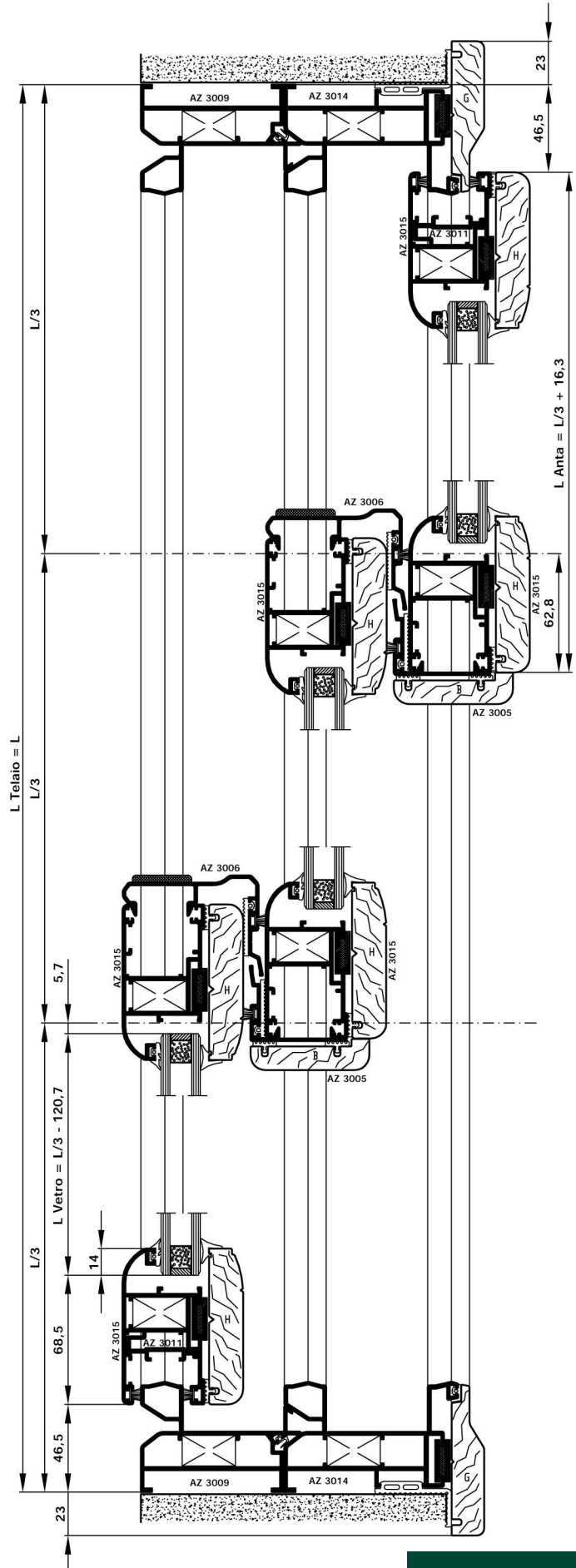
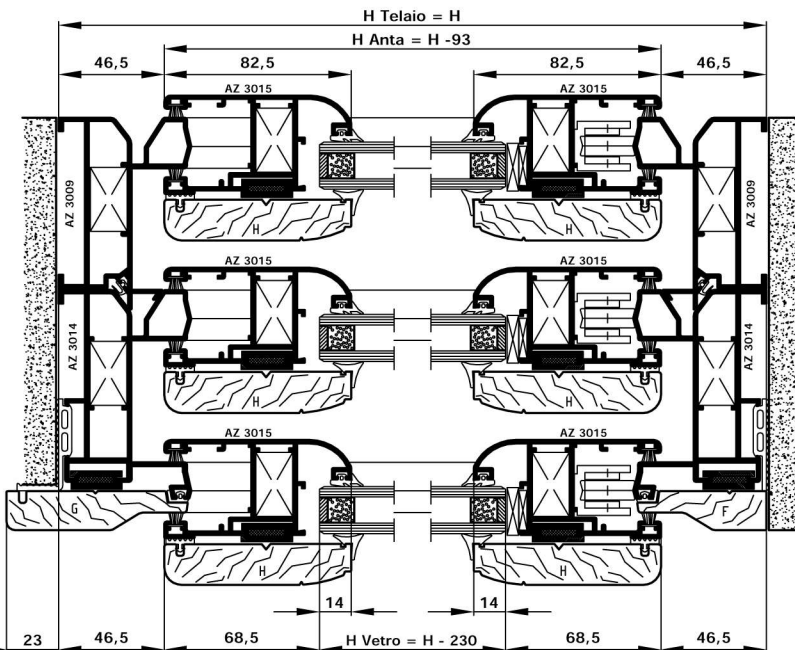

CALCOLO PESO PROFILI		TOTALE
Profili Orizz.	Kg/ml 13,3 x L	KG
Profili Vert.	Kg/ml 16,2 x H	
TOTALE		

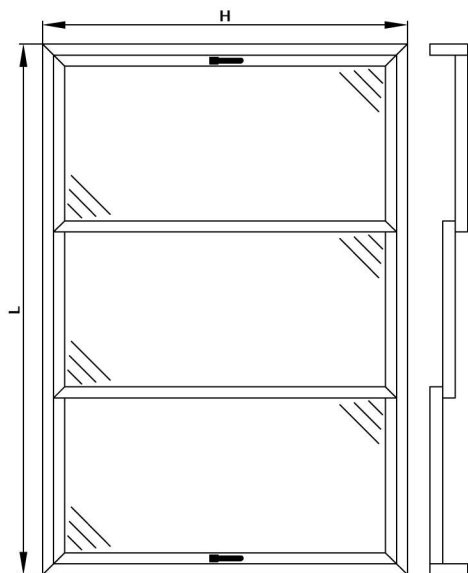

CALCOLO LUNGHEZZE TEORICHE LEGNI		TOTALE
B	2H - 186 mm	ml
F	L	
G	2H + L + 138 mm	
H	6H + 3L - 460 mm	



DISTINTA TAGLIO PROFILI

Nr. Pezzi	CODICI	DESCRIZIONE	TAGLIO
2	AZ 3009	MONTANTE TELAIO	 H
2	AZ 3014	MONTANTE TELAIO	 H
2	AZ 3009	TRAVERSO TELAIO	 L
2	AZ 3014	TRAVERSO TELAIO	 L
6	AZ 3015	MONTANTE ANTA	 H-93
6	AZ 3015	TRAVERSA ANTA	 L/3+16,3
2	AZ 3005	RISCONTRO CENT. INT.	 H-93
2	AZ 3006	RISCONTRO CENT. EST.	 H-93
2	AZ 3011	ASTA DI CHIUSURA	 H-93

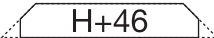
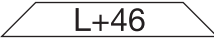
DISTINTA TAGLIO LEGNI

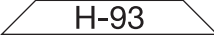
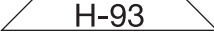
Nr. Pezzi	CODICI	DESCRIZIONE	TAGLIO
2	G	LEGNO TELAIO MONT.	 H+46
1	G	LEGNO TELAIO TRAV. SUP.	 L+46
1	F	LEGNO TELAIO TRAV. INF.	 L
6	H	LEGNO ANTA MONT.	 H-93
6	H	LEGNO ANTA TRAV.	 L/3+16,3
2	B	LEGNO RISCONTRO CENT.	 H-93

GUARNIZIONI

ART.	DESCRIZIONE	N° P.zzi
Rg 339	G. ISOL. LEGNO-ALL TELAIO	2L + 2H
Rg 354	G. ISOLAMENTO SOGLIA	2L + 2H
Rg 301	G. A SPAZZOLA	8L + 12H
Rg 342	G. ISOL. LEGNO-ALL LEGNO	12L + 7H
Rg 345	G. VETRO INTERNA	6L + 6H
Rg 351	G. VETRO ESTERNA	6L + 6H
Rg 340	G. NODO CENTRALE ANTA	4L
Rg 402	G. NODO CENTRALE TELAIO	2L + 2H

ACCESSORI



ART.	DESCRIZIONE	N° P.zzi
Ra 1033	CAPPETTA DI SCARICO ACQUA	3
Ra 2302	BLOCCHETTO UNIONE LEGNO ALLUMINIO	1 ogni 200 mm
Ra 2600	REGOLATORE A MURO	12
Ra 2601	BOCCOLA SCARICO ACQUA	6
Ra 2608	SQUADRETTA PER TELAIO E ANTA	8
Ra 2618	SQUADRETTA DI ALLINEAMENTO ANTE	12
Ra 2603	TASSELLO AMMORTIZZATORE E ANTIFILAMENTO ANTA	6
Ra 2609	TAPPO COPRILAVORAZIONE	8
Ra 2606	TASSELLO DI TENUTA CENTRALE	4
Ra 2607	CARRELLO SCORREVOLE REGISTRABILE PORTATA MASSIMA PER ANTA 150 Kg	6

È ESCLUSA LA FERRAMENTA DI MOVIMENTAZIONE

DISTINTA TAGLIO PROFILI

Nr. Pezzi	CODICI	DESCRIZIONE	TAGLIO
2	AZ 3014	MONTANTE TELAIO	 H
2	AZ 3014	TRAVERSO TELAIO	 L
8	AZ 3015	MONTANTE ANTA	 H-93
8	AZ 3015	TRAVERSA ANTA	 L/4+10,8
2	AZ 3005	RISCONTRO CENT. INT.	 H-93
2	AZ 3006	RISCONTRO CENT. EST.	 H-93
3	AZ 3011	ASTA DI CHIUSURA	 H-93

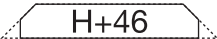
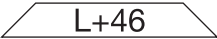
DISTINTA TAGLIO LEGNI

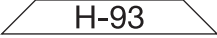
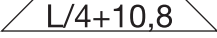
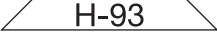
Nr. Pezzi	CODICI	DESCRIZIONE	TAGLIO
2	G	LEGNO TELAIO MONT.	 H+46
1	G	LEGNO TELAIO TRAV. SUP.	 L+46
1	F	LEGNO TELAIO TRAV. INF.	 L
8	H	LEGNO ANTA MONT.	 H-93
8	H	LEGNO ANTA TRAV.	 L/4+10,8
2	B	LEGNO RISCONTRO CENT.	 H-93

GUARNIZIONI

ART.	DESCRIZIONE	N° P.zzi
Rg 339	G. ISOL. LEGNO-ALL TELAIO	2L + 2H
Rg 354	G. ISOLAMENTO SOGLIA	2L + 2H
Rg 301	G. A SPAZZOLA	10L + 8H
Rg 342	G. ISOL. LEGNO-ALL LEGNO	14L + 5H
Rg 345	G. VETRO INTERNA	8L + 8H
Rg 351	G. VETRO ESTERNA	8L + 8H
Rg 340	G. NODO CENTRALE ANTA	4L

ACCESSORI

ART.	DESCRIZIONE	N° P.zzi
Ra 1033	CAPPETTA DI SCARICO ACQUA	4
Ra 2302	BLOCCHETTO UNIONE LEGNO ALLUMINIO	1 ogni 200 mm
Ra 2600	REGOLATORE A MURO	14
Ra 2601	BOCCOLA SCARICO ACQUA	6
Ra 2608	SQUADRETTA PER TELAIO E ANTA	24
Ra 2618	SQUADRETTA DI ALLINEAMENTO ANTE	16
Ra 2603	TASSELLO AMMORTIZZATORE E ANTISFILAMENTO ANTA	8
Ra 2609	TAPPO COPRILAVORAZIONE	8
Ra 2606	TASSELLO DI TENUTA CENTRALE	6
Ra 2607	CARRELLO SCORREVOLE REGISTRABILE PORTATA MASSIMA PER ANTA 150 Kg	8

È ESCLUSA LA FERRAMENTA DI MOVIMENTAZIONE